

## Event Bulletin 01 - Technical

GLOBAL ROTAX MAX Challenge Technical Regulation 2024

Valid from: 2024 April 08

Addendum/changes (highlighted in yellow) to Global RMC Technical Regulation 2024, Edition 2023 11 13  
Version 2

## 5.6 INLET SYSTEM

### 5.6.1 Reed valve assy.

The reed valve assy. is equipped with 2 petal stops and 2 reeds, each having 3 petals.

	Thickness	Tolerance
Reed Valve	0,6 mm	+0,10 mm -0,10 mm

Flattening of the curved reed valve stopper plates is forbidden.

The minimum gap between the 2 stopper plates must be greater than **16.70mm**.

The measurement must be taken using a digital calliper from the inside surface of the stopper plates in line with the middle of each reed petal, as indicated by the red lines in the picture.



### 6.17 125 MICRO MAX

A specific Exhaust system has to be used for the 125 Micro MAX engine. ROTAX Part number 273136

The Exhaust external body is a common component to Mini MAX, but with alternative internal components (Inserts).

The silencer must be mounted in a Position where the direction of the 90° elbow outlet (direction of the hot exhaust gasses) does not harm any component of the chassis.

The exhaust must be mounted and secured in such a way to ensure a full sealing around the exhaust socket and the gasket ring.

The measurements in the diagram to the right are as follows:

- (a) 580 mm +/- 5mm
- (b) 299 mm +/- 5mm
- (c) 42 mm +/- 3mm

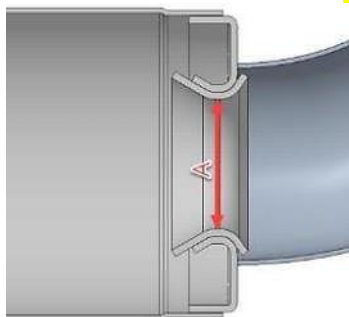
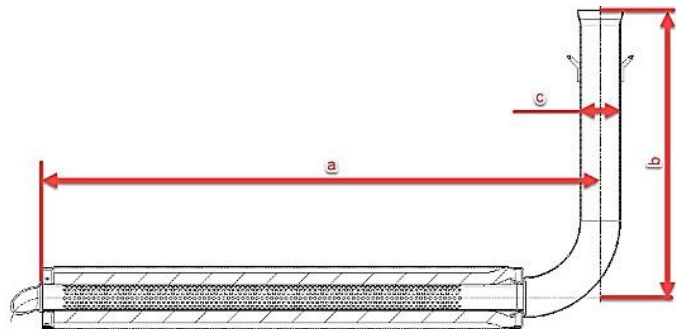

A solid flat plate measuring 28.0mm and 1.5mm thick **must not** pass through Section "A" and

a steel ball with a 26.0mm diameter must be able pass through Section "A" in the below diagram from the inlet and through the 90- degree elbow completely. All exhaust gases must pass through Section "A".

(Internal exhaust components must first be removed)

The inner measurement of the exhaust system silencer end (a) in the diagram must be a maximum of 63.0 mm.

**Note**

This is not a measurement of the perforated tube

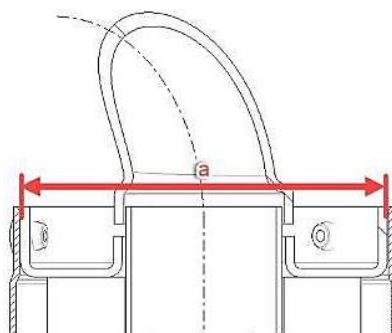

The Exhaust must be installed firmly to the chassis using a rigid mount/s.

The Exhaust must be mounted to the rigid mount/s using 2 ROTAX silent blocks. (Part 660920 and or 260657 allowed).

The deflection of the 2 silent blocks is the only Exhaust movement allowed.

The Exhaust must be mounted in a neutral Position with no stress on the 2 silent blocks.

### 125 Micro MAX Perforated tube

ROTAX part number: 273212

The measurements in the diagram below are as follows:

- (a) at least 498 mm
- (b) minimum outside diameter of 61 mm
- (c) maximum outside diameter of 26 mm
- (d) minimum length 63 mm

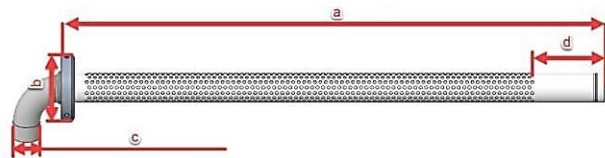

The measurement in the diagram to the right is as follows:

- (a) minimum outside diameter of 26.0mm



The only legal Isolation matting for 125 Micro MAX is:

ROTAX part number 297982	Measurement	Tolerance
<b>New size minimum</b>	480 x 270 mm	+10 mm
		-10 mm
<b>New weight</b>	207 Gram	+31 Gram
		-31 Gram
<b>Used weight (old)</b>	245 Gram	+105 Gram
		-105 Gram

### Note

The only exhaust system allowed for racing in the 125 Micro and 125 Mini MAX category's is the MY2020 version.

The exhaust has 3 clear visual differences to identify the MY2020 version.

1. Exhaust hooks
2. Connecting socket / ball joint connect at manifold
3. Wall thickness of the exhaust system is 1.0mm (older exhaust system which is not allowed for racing has a wall thickness of 1.5mm)

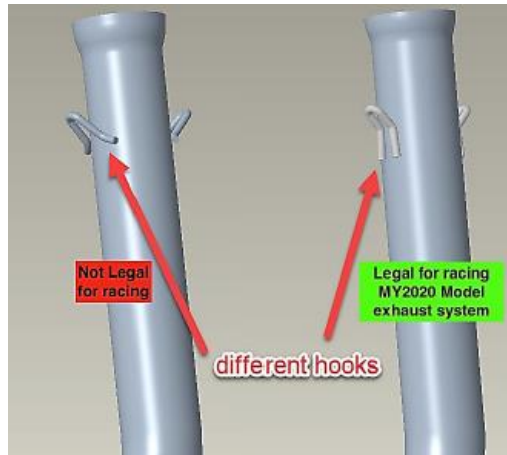

### 6.17 125 MINI MAX

A specific Exhaust system has to be used for the 125 Mini MAX engine. ROTAX Part number 273137

The Exhaust external body is a common component to Micro MAX but with alternative internal components.

The silencer must be mounted in a Position where the direction of the 90° elbow outlet (**direction of the hot exhaust gasses**) does not harm any component of the chassis.

The exhaust must be mounted and secured in such a way to ensure a full sealing around the exhaust socket and the gasket ring.

The measurements in the diagram below are as follows:

- (a) 580 mm +/- 5mm
- (b) 299 mm +/- 5mm
- (c) 42 mm +/- 3mm

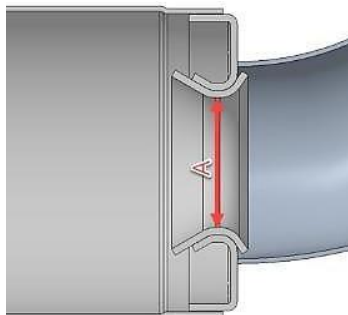
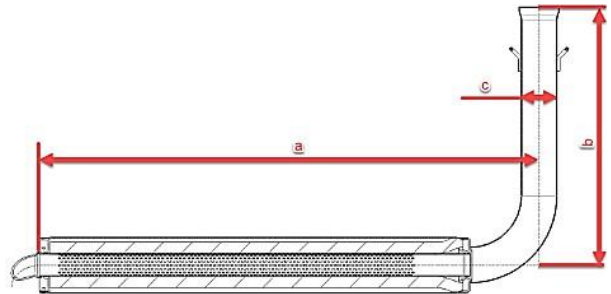

A solid flat plate measuring 28.0mm and 1.5mm thick **must not** pass through Section "A" and

a steel ball with 26.0mm diameter must be able pass through Section "A" in the below diagram from the inlet and through the 90-degree elbow completely. All exhaust gases must pass through Section "A".

(Internal exhaust components must first be removed)

The inner measurement of the exhaust system silencer end (a) in the below diagram must be a maximum of 63.0 mm.

**Note**

This is not a measurement of the perforated tube

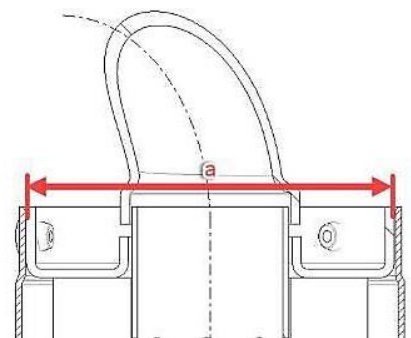

The Exhaust must be installed firmly to the chassis using a rigid mount/s.

The Exhaust must be mounted to the rigid mount/s using 2 ROTAX silent blocks. (Part 660920 and or 260657 allowed).

The deflection of the 2 silent blocks is the only Exhaust movement allowed.

The Exhaust must be mounted in a neutral Position with no stress on the 2 silent blocks.

125 Mini MAX Perforated tube

ROTAX Part number 273211

The measurements in the diagram below are as follows:

- (a) at least 481mm
- (b) minimum outside diameter of 61 mm
- (c) maximum outside diameter of 26 mm
- (d) at least 63 mm

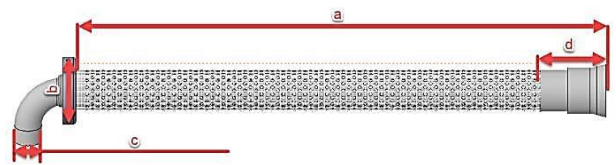

**Note**

Mini MAX perforated tube has a stamped ID marker "X" visible externally.

The only legal Isolation matting for 125 Mini MAX is:

ROTAX part number 297985	Measurement	Tolerance
<b>New size minimum</b>	490 x 180 mm	+10 mm
		-10 mm
<b>New weight</b>	141 Gram	+22 Gram
		-22 Gram
<b>Used weight (old)</b>	230 Gram	+120 Gram
		-120 Gram

## 6.10

### CARBURETTOR

Needle valve assembly stamped "150"

A pin gauge measuring 1.56mm must not pass through the bore of the Needle valve.

Needle of needle valve marked with diamond symbol "INC" only.



### 6.11 FUEL PUMP, FUEL FILTER

Its is advised and permitted to use fuel hose clamps on all fuel and pulse lines to provide a secure seal.

### 2.11 FUEL / OIL

- XPS CASTOR RACING OIL 2T oil mixed at a 2% ratio is mandatory

Signed: Nigel Edwards – Race Director

Date: 18/04/2024

Time: 12:30